

# ULTRA VIOLET LED Lamp

# NS375L-ERLM

## (1) Absolute Maximum Ratings (Ta=25°C)

Item	Symbol	Maximum Rating	Unit
DC Forward Current	$I_F$	25	mA
Pulse Forward Current*	$I_{FP}$	100	mA
Reverse Current	$I_R$	85	mA
Power Dissipation	$P_D$	100	mW
Operating Temperature	$T_{OPR}$	-30 to +80	°C
Storage Temperature	$T_{STG}$	-30 to +85	°C
Soldering Temperature	$T_{SOL}$	260(within 10sec)	°C

\* Conditions : Duty Cycle  $\leq 1/10$ , Pulse Width  $\leq 0.1$ msec

## (3) Dimension (Unit : mm)

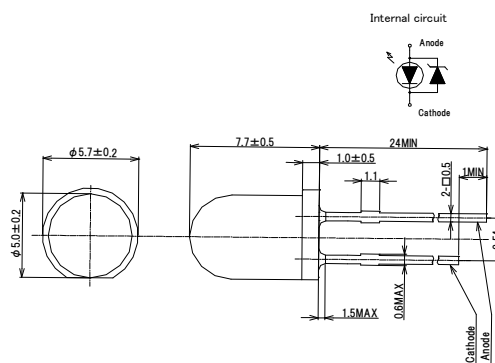

## (2) Optical and Electrical Characteristics (Ta=25°C)

Item	Symbol	Condition	Min.	Typ.	Max.	Unit	
Forward Voltage	NS375L	$V_F$	$I_F=20$ mA	3.2	3.6	4.2	V
Peak Wavelength*1	NS375L	$\lambda_p$	$I_F=20$ mA	375	-	380	nm
Full Width at Half Maximum	NS375L	$\Delta\lambda$	$I_F=20$ mA	10	-	20	nm
Optical Output Power *2	Po	$I_F=20$ mA	Refer to Rank Information			mW	

\*1 Measurement error is  $\pm 2$ nm

\*2 Measurement error is  $\pm 10\%$

## Rank Information

Rank	Optical Output Power			NS375L
	Min.	Typ.	Max.	
				-ERLM
12	14.0	-	17.4	○
13	17.4	-	21.0	○
14	21.0	-	25.0	ask*3

\*3 Please contact us for availability.

## (4) Directive Characteristics (Ta=25°C)

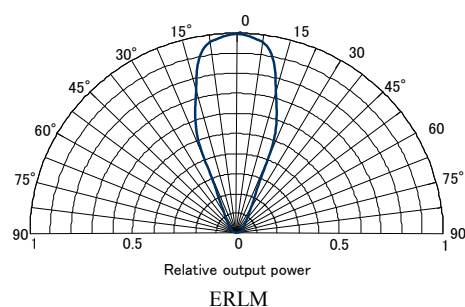

## CAUTION

- LEDs emit very strong UV radiation.
- Don't look directly into the LED light. UV radiation can harm your eyes.
- To prevent even inadequate exposure, wear protective eyewear.
- If LEDs are embedded in devices, please indicate warning labels against the UV light LED used.
- Keep out of reach of children.

Specification and dimension are subject to change for improvement without notice.